



HONSEL

Umformtechnik GmbH

VNG 802

- Ⓓ Bedienungsanleitung
- ⒼⒷ Instruction manual
- Ⓕ Notice d'instruction
- Ⓔ Guia de instrucciones
- Ⓘ Istruzioni per l'uso
- ⓃⓁ Gebruiksaanwijzing
- Ⓔ Bruksanvisning
- Ⓔ Bruksanvisning
- ⒹⓀ Betjeningsvejledning
- ⒻⒻ Käyttöohje
- ⒼⓁ Instrukcja obsługi
- ⒹⓇ Kullanım El Kitabı





- (D) Vor der Benutzung überprüfen**
- (GB) Check before use**
- (F) Verifier avant utilisation**
- (E) Antes de la utilizacion compruebe**
- (I) Verificare prima dell'uso**
- (NL) Controleren voor het gebruik**
- (S) Kontrollera före användadet**
- (N) Kontroller før bruk**
- (DK) Kontroller følgende før brug**
- (SF) Tarkista ennen käyttöä**
- (PL) Przed użyciem sprawdź**
- (TR) Kullanmadan önce kontrol edin**

(D) ÖLSTAND

(GB) OIL LEVER

(F) NIVEAU HUILE

(E) NIVEL DE ACEITE

(I) LIVELLO OLIO

(NL) OLIEPEIL

(S) OLJENIVÅ

(N) OLJENIVÅ

(DK) OLJESTAND

(SF) ÖLJYN MÄÄRÄ

(PL) POZIOM OLEJU

(TR) YAĞ SEVİYESİ

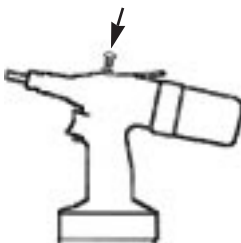

(D) BETRIEBSDRUCK

(GB) OPERATING PRESSURE

(F) PRESSION D'UTILISATION

(E) PRESSION DE UTILIZACION

(I) PRESSIONE DI UTILIZZO

(NL) LUCHTDRUK

(S) ARBETSTRYCK

(N) ARBEIDSTRYKK

(DK) ARBEJDSSTRYK

(SF) KÄYTTÖPAINE

(PL) CIŚNIENIE SPRĘŻONEGO POWIETRZA

(TR) ÇALIŞMA BASINCI



(D) ZUSTAND GEWINDEDORN

(GB) CONDITION OF THE MANDREL

(F) ETAT TIGE DE TRACTION

(E) ESTADO DEL MANDRIL

(I) STATU DELLE ASTA FILETTATA

(NL) STAAT VAN DE DRAADSTIFT

(S) DRAGDORN KONDITION

(N) RENE GJENGETOLK

(DK) GEVINDDORN TILSTAND

(SF) KIERREKARA ASENTO

(PL) STAN TRZPIENA



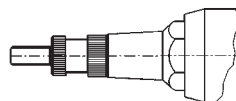





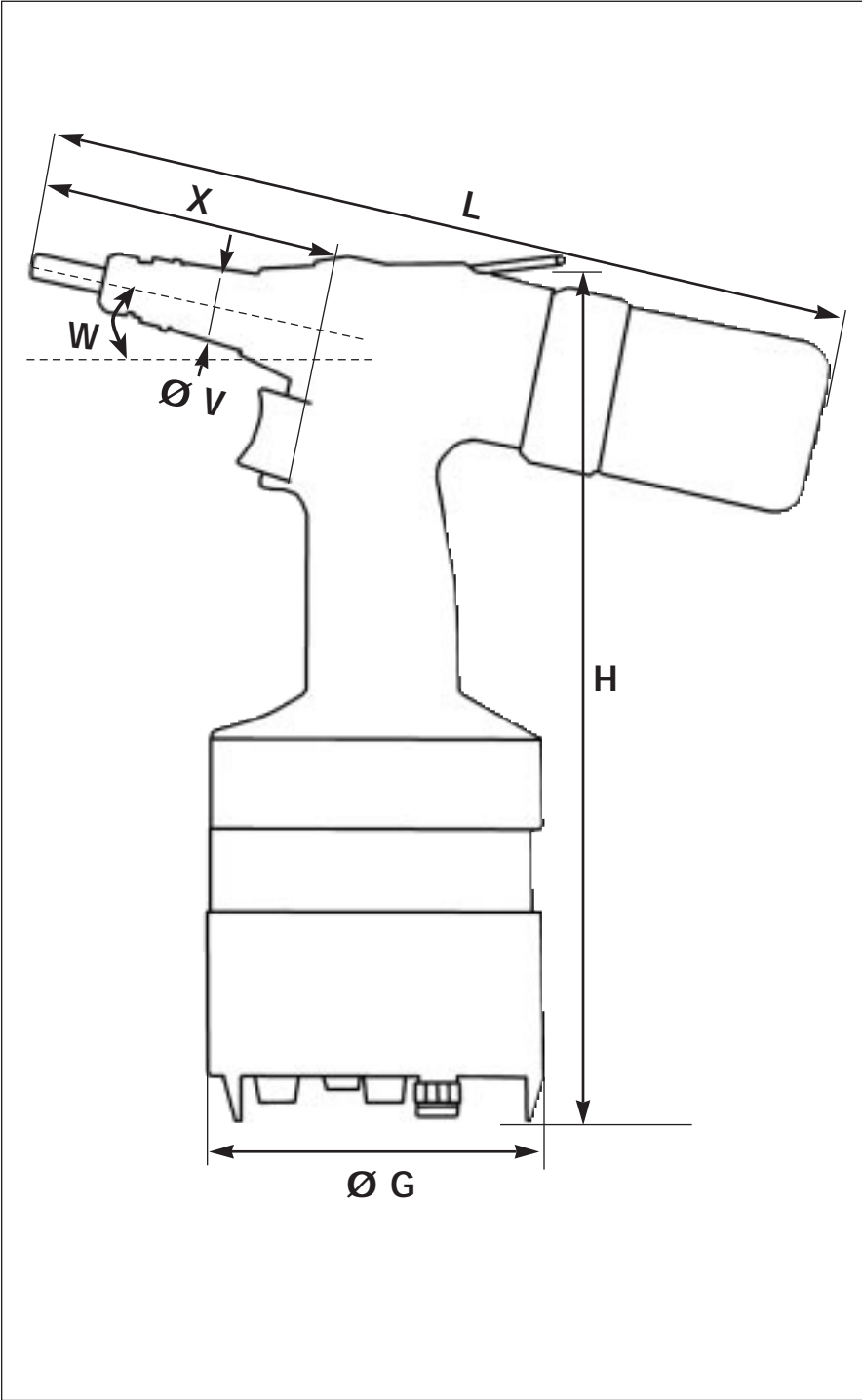





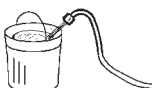

(TR) ÇENELERİN ŞAPLAMA





- D** – VERWENDEN SIE ORIGINALTEILE
– NEHMEN SIE KEINE REPARATUREN SELBST VOR
– BEI STÖRUNGEN NEHMEN SIE MIT IHREM HÄNDLER KONTAKT AUF
– ARBEITEN SIE NICHT BEI EINEM BETRIEBSDRUCK VON MEHR ALS 8 BAR
– RICHTEN SIE BEI DER BENUTZUNG DIESES WERKZEUG NIEMALS AUF PERSONEN
– TRAGEN SIE BEI DER BENUTZUNG EINE SCHUTZBRILLE
– TRAGEN SIE BEI DER BENUTZUNG GEHÖRSCHUTZ
- GB** – ONLY USE ORIGINAL PARTS
– DO NOT MAKE REPAIRS YOURSELF
– IN THE EVENT OF PROBLEMS, PLEASE CONTACT YOUR LOCAL DEALER
– DO NOT OPERATE AT A PRESSURE OF MORE THAN 8 BAR
– NEVER POINT THIS TOOL TOWARDS ANOTHER PERSON
– WEAR SAFETY GLASSES WHEN USING THIS TOOL
– WEAR EAR PROTECTORS WHEN USING THIS MACHINE
- F** – N'UTILISER QUE DES PIÈCES D'ORIGINES
– NE PAS EFFECTUER DE REPARATIONS VOUS MÊME
– EN CAS D'ANOMALIE, VEUILLER CONTACTER VOTRE DISTRIBUTEUR
– NE PAS UTILISER UNE PRESSION SUPERIEURE A 8 BAR
– NE DIRIGEZ JAMAIS CET OUTIL VERS UNE PERSONNE
– PORTEZ DES LUNETTES DE PROTECTION LORS DE L'UTILISATION
– PORTEZ UN CASQUE D'ISOLATION PHONIQUE PENDANT L'UTILISATION
- E** – UTILICE UNICAMENTE PIEZAS DE ORIGEN
– NO EFECTUE REPARACIONES USTED MISMO
– EN CASO DE ANOMALIA, PONGASE EN CONTACTO CON SU DISTRIBUIDO
– NO USE UNA PRESION DE UTILIZACION SUPERIOR A 8 BARES
– NO DIRIJA NUNCA ESTA HERRAMIENTA HACIA UNA PERSONA
– LLEVE GAFAS DE PROTECCION DURANTE LA UTILIZACION
– LLEVE UN CASCO DE AISLAMIENTO FONICO DURANTE LA UTILIZACION
- I** – UTILIZZARE UNICAMENTE RICAMBII ORIGINALI
– NON PUNTARE MAI L'UTENSILE CONTRO TERZI
– IN CASO DI ANOMALIA CONSULTARE IL VOSTRO DISTRIBUTORE
– NON USARE MAI UNA PRESSIONE D'UTILIZO SUPERIORE A 8 BAR
– NON PUNTARE MAI LO STRUMENTO CONTRO UNA PERSONA
– METTERE OCCHIALI DI PROTEZIONE DURANTE L'UTILIZO
- NL** – ALLEEN ORGINELE ONDERDELEN GEBRUIKEN
– ZELF GEEN REPARATIES UITVOEREN
– BIJ STORINGEN CONTACT OPNEMEN MET UW LEVERANCIER
– GEEN DRUK HOGER DAN 8 BAR GEBRUIKEN
– DIT GEREEDSCHAP NOOIT OP IEMAND RICHTEN
– TIJDEN GEBRUIK GEHOOR- EN GEZICHTS-BESCHERMING DRAGEN
- S** – ANVÄND ENDAST ORIGINALDELAR
– REPARERA EJ SJÄLV
– VID EV. DRIFTSTÖRNINGAR KONTAKTA DIN LEVERANTÖR
– ANVÄND EJ HÖGRE TRYCK ÄN 8 BAR
– RIKTA ALDRIG VERKTÖGET MOT ANDRA PERSONER
– ANVÄND SKYDDSGLASÖGON
– ANVÄND HÖRSELSKYDD
- N** – KONTROLLER TRYKKLUFTSLANGEN OG KOPLINGEN FØR BRUK
– ARBEIDSTRYKKET MÅ IKKE OVERSTIGE 8 BAR
– KOBLE FRA TRYKKLUFTSLANGEN FØR DU UTFØRER NOE ARBEIDE PÅ SELVE VERKTØYET
– VED PROBLEMER, KONTAKT SELGER
– SIKT ALDRIG MED VERKTØYET PÅ ANDRE MENNESKER
– BRUK VERNEBRILLER OG VED BEHOV HØRSELVERN
– BRUK VERKTØYET KUN FOR DET RIKTIGE FORMÅLET
- DK** – ANVEND KUN ORIGINALDELE
– REPARER ALDRIG SELV VÆRKTØJET
– KONTAKT DERES LEVERANDØR VED VÆRKTØJSPROBLEMER
– VÆRKTØJET MÅ IKKE BRUGES VED MERE END 8 BAR TRYK
– PEG ALDRIG VÆRKTØJET MOD EN ANDEN PERSON
– BÆR ALTID BESKYTTELSBRILLER UNDER ARBEJDET
– BÆR ALTID HØREVÆRN UNDER ARBEJDET
- SF** – KÄYTÄ VAIN ALKUPERÄISIÄ VARAOSIA
– ÄLÄ TEE ITSE KORJAUSTÖITÄ
– OTA ONGELMATAPAUKSISSA YHTEYTTÄ LAITTEEN MYYNNEESEEN LIIKKEESEEN
– ÄLÄ KÄYTÄ YLI 8 BARIN PAINETTA
– LAITTEELLA EI SAA OSOITTA MUITA IHMISIÄ KOHTI
– KÄYTÄ SUOJALASEJA JA MAHDOLLISESTI MYÖS KUULOSUOJAIMIA
- PL** – STOSOWAĆ WYŁĄCZNIE ORIGINALNE CZĘŚCI ZAMIENNE
– NIE PODEJMOWAĆ SAMODZIELNYCH REPARATUR
– W PRZYPADKU USTEREK SKONTAKTOWAĆ SIĘ Z PUNKTEM SPRZEDAŻY
– NIE STOSOWAĆ SPRĘŻONEGO POWIETRZA POWYŻEJ 8 BAR
– NIGDY NIE KIEROWAĆ NARZĘDZIA W STRONĘ OSÓB
– PODCZAS PRACY NOSIĆ OKULARY OCHRONNE
– STOSOWAĆ ŚRODKI OCHRONY SŁUCHU
- TR** – SADECE ORJİNAL PARÇA KULLANIN
– KENDİNİZ TAMİRAT YAPMAYIN
– SORUN HALİNDE BÖLGE BAYİNİZLE TEMAS KURUN
– 8 BARDAN YÜKSEK BASINÇTA ÇALIŞTIRMAYINIZ
– BU ALETİ BAŞKA BİR ŞAHSA DOĞRU TUTMAYINIZ
– BU ALETİ KULLANIRKEN EMNİYET GÖZLÜĞÜ Ü TAKINIZ
– BU MAKİNEYİ KULLANIRKENKULAK KORUYUCUSU KULLANIN



	 <p>VNG 802</p>		 <p>VNG 802</p>
 <p>P</p>	<p>5 – 7 bar</p>	<p>X</p>	<p>58</p>
 <p>F</p>	<p>29.000 N</p>	<p>Ø G</p>	<p>90</p>
 <p>S</p>	<p>max. 7 mm</p>	 <p>Dmin – Dmax</p>	<p>M 4 – M 10</p>
	<p>7,5 l</p>	 <p>dmax</p>	<p>M 4 – M 8</p>
	<p>2,7 kg</p>		
<p>L</p>	<p>280 mm</p>		<p>1/4 "</p>
<p>H</p>	<p>300 mm</p>		<p>4,5 E/50 C</p>
 <p>W</p>	<p>12°</p>		<p>< 85 dB(A)</p>
<p>Ø V</p>	<p>26,0</p>		<p>< 2,5 m/s²</p>



Automatisches Auffädeln der Blindnietmutter

Automatisches Auffädeln durch leichten Druck der Blindnietmutter gegen den Gewindedorn (Drücken = Auffädeln/Rechtslauf)

Automatic feeding of blind rivet nuts

Automatic feeding by pressing the rivet nut slightly against the mandrel (press = mandrel turns right)

Vissage automatique de l'écrou à sertir

Vissage automatique de l'écrou par simple pression de celui-ci sur la tige de traction (pousser sur la tige = vissage)

**Drücken =
Auffädeln/Rechtslauf**

**Press = mandrel
turns right**

**Pousser sur la tige =
vissage**





Einstellbare Abfädelzeit

Messing-Rändelrad zur Einstellung der Abfädelzeit
(Herausdrehen = Abfädelzeit verkürzen)

Spin off time

Turn knurled brass knob for adjustment off spin off time
(unscrew counter clock wise = decrease spin off time)

Temporisation du dévissage

Molette en laiton permettant le réglage de la temporisation du dévissage (dévisser = raccourcissement de la temporisation)

Herausdrehen =
Abfädelzeit ver-
kürzen

Unscrew =
decrease
spin off time

Dévisser =
raccourcissement
de la temporisation





Einstellbare Auffädelgeschwindigkeit

Messing-Rändelrad zur Einstellung der Auffädelgeschwindigkeit (Herausdrehen = Auffädelgeschwindigkeit erhöhen)

Adjustable speed for feeding

Turn knurled brass knob for adjustment off feeding speed (revolutions of the mandrel)
(unscrew counter clock wise = increase speed)

Réglage de la vitesse de dévissage

Molette en laiton permettant le réglage de la vitesse de dévissage (dévisser = augmentation de la vitesse)



(Herausdrehen =
Auffädelgeschwin-
digkeit erhöhen)

(unscrew =
increase speed)

(dévisser =
augmentation
de la vitesse)



Manuelle Linkslaufauslösung

Messingknopf zur Auslösung des manuellen Linkslaufes
(gedrückt halten = Linkslauf/Abfädeln)

Manual spin off

Brass push button for manual spin off
(hold push button down = spin off)

Dévisage manuel

Bouton en laiton pour le déclenchement manuel du dévissage
(maintenir enfoncé = dévissage)



gedrückt halten =
Linkslauf/Abfädeln

hold push button
down =
spin off

maintenir enfoncé =
dévissage



SW 20
SW 24



SW 24



SW 10
SW 12





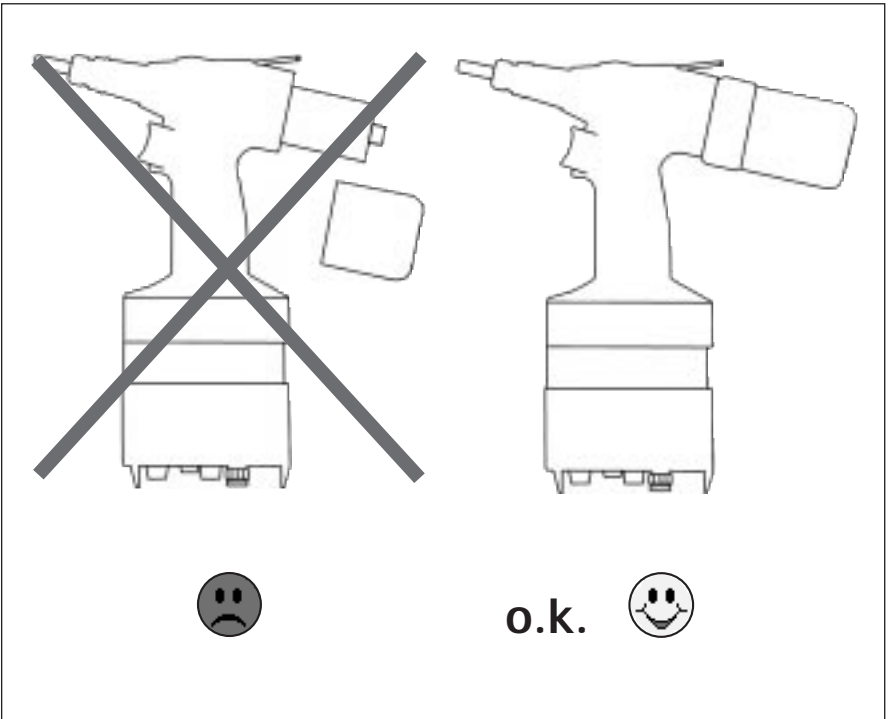
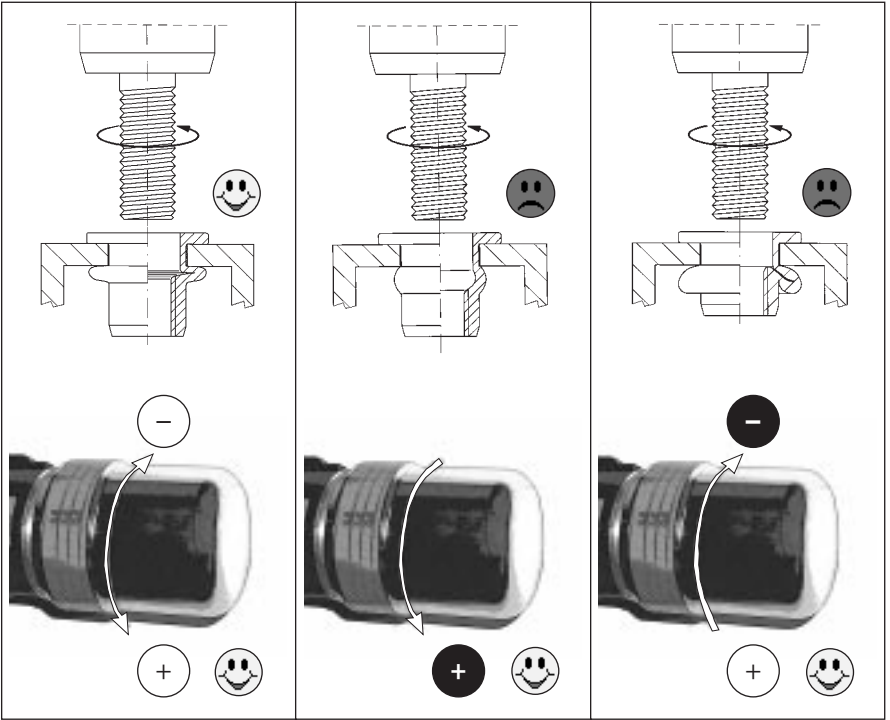

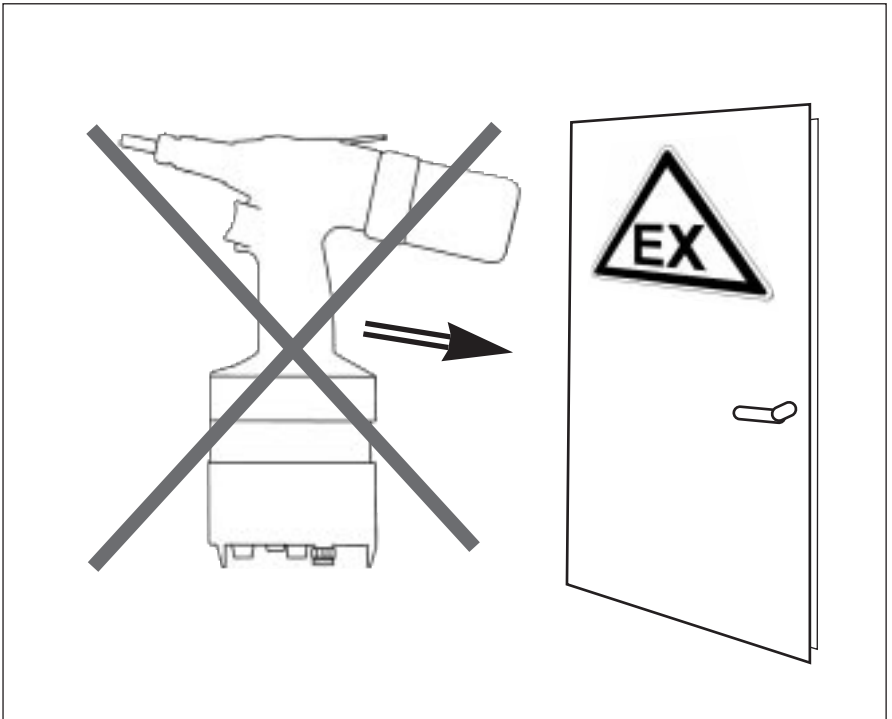
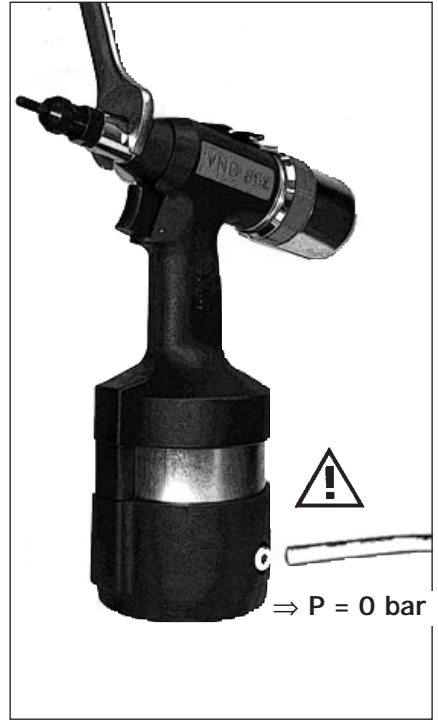
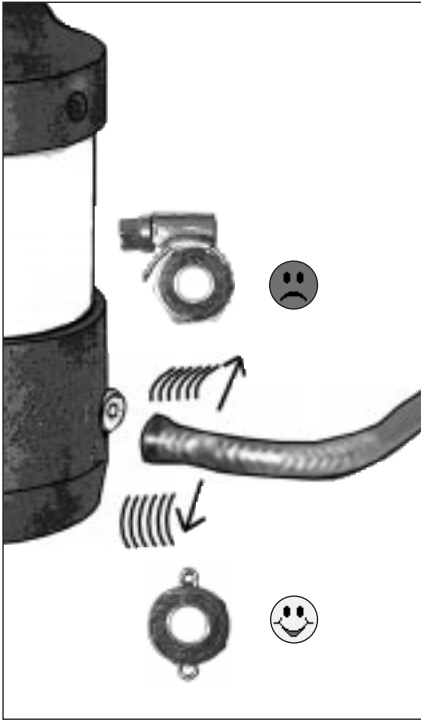

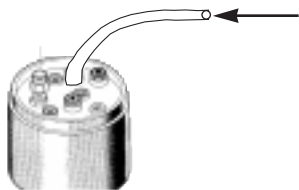

- (D) TROCKENE LUFT
- (GB) DRY AIR
- (F) AIR SEC
- (E) AIRE SECO
- (I) ARIA SECCA
- (NL) DROGE LUCHT
- (S) TØRR LUFT
- (N) TØRR LUFT
- (DK) TØR LUFT
- (SF) KUIVAA ILMAA
- (PL) SUCHÈ, SPRÈZONE POWIETRZE
- (TR) KURU HAVA

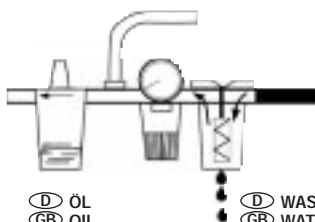

- (D) ÖL
 - (GB) OIL
 - (F) HUILE
 - (E) ACIETE
 - (I) OLIO
 - (NL) OLIE
 - (S) OLJA
 - (N) OLJE
 - (DK) OLIE
 - (SF) OLJYA
 - (PL) OLEJ
 - (TR) YAĞ
- (D) WASSER
 - (GB) WATER
 - (F) EAU
 - (E) AQUA
 - (I) AQUA
 - (NL) WATER
 - (S) VANN
 - (N) VANN
 - (DK) VAND
 - (SF) VESI
 - (PL) WODA
 - (TR) SU

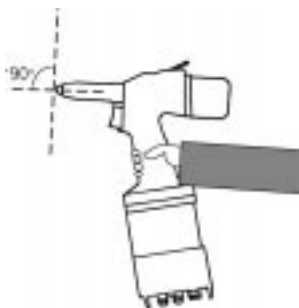

$$a - b = s$$

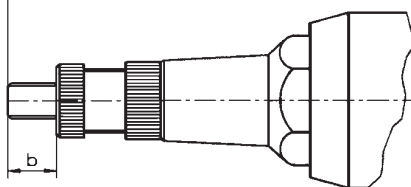
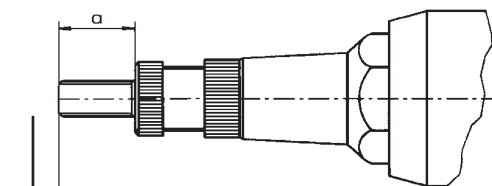

VNG 802

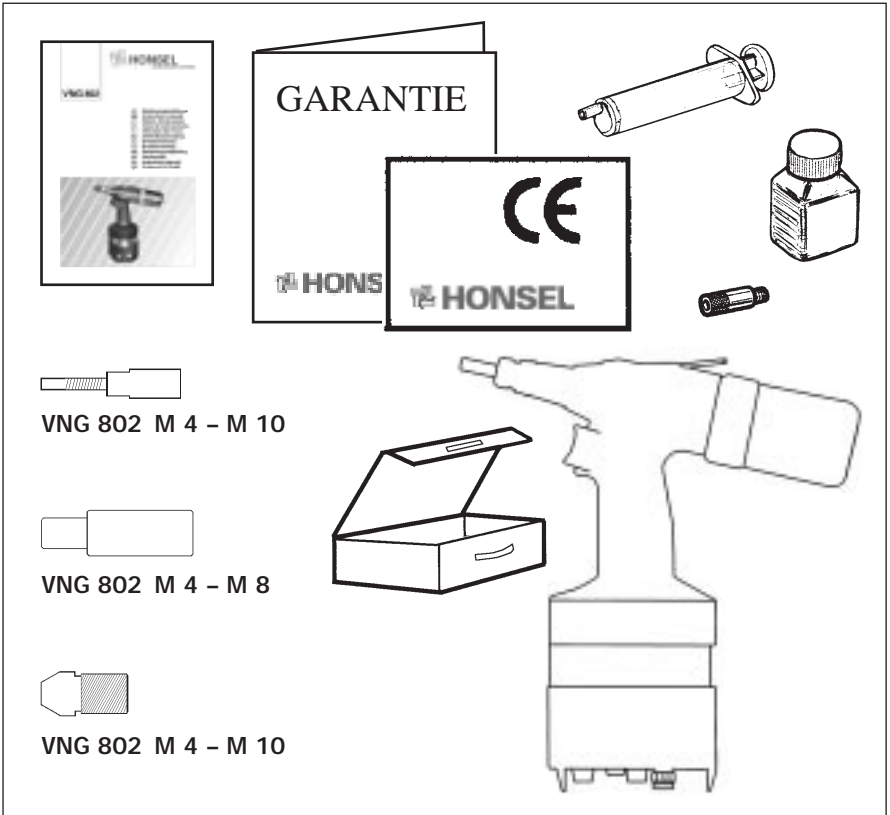
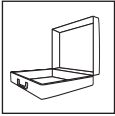
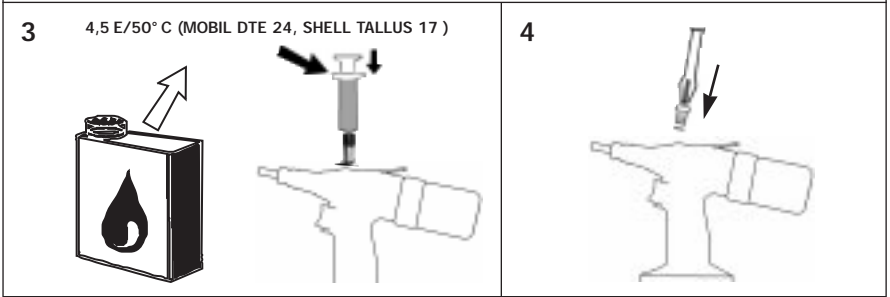
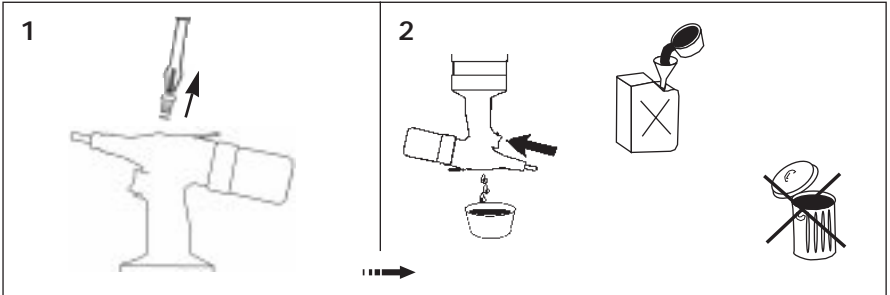

VNG 802

Deutschland:

VVG

Befestigungstechnik
GmbH & Co.
Haberstraße 29
24537 Neumünster
Postfach 2752
24517 Neumünster
Tel. +49 (0) 43 21/96 7171
Fax +49 (0) 43 21/96 7196

Frankreich:

Alfred Honsel s.a.r.l.

20, rue du Lhotaud
Boîte Postale 1
F-25560 Frasne
Tel. +33 (3) 381498946
Fax +33 (3) 381498947

VVG France s.a.r.l.

20, rue du Lhotaud
Boîte Postale 1
F-25560 Frasne
Tel. +33 (3) 381498900
Fax +33 (3) 381498699

Belgien:

Combori N.V.

Blancefloerlaan 181
B-2050 Antwerpen
Tel. +32 (0) 3/2101211
Fax +32 (0) 3/2195804

Dänemark:

OJD Trading ApS

Lerbaekvej 16 + 18
DK-2680 Solroed Strand
Tel. (+45) 53 14 14 28
Fax (+45) 53 14 64 78
e-mail: ojd@ojd.dk

Finnland:

Oy Mercantile AB

Mercantile Pultti
Hakkilankaari 2
SF-01380 Vantaa
Tel. +358 9 34 501
Fax +358 9 873 3662

Niederlande:

Borstlap B.V.

Postbus 50 34
NL-5004 EA Tilburg
Tel. +31 (0) 13/5941234
Fax +31 (0) 13/5941212

Norwegen:

Tingstad AS

Stalfjæra 17
Kalbakken
Postboks 83
N-0902 Oslo
Tel. +47/22169400
Fax +47/22164583

Italien:

Unicom SRL

Rappresentanze Industriali
Via Arona, 37
I-10145 Torino
Tel. +39 (0) 117716090
Fax +39 (0) 117716127

Polen:

PHU Marsel BIS

Marek Chlebosz
UL. Soldka 16 d
PL-80299 Gdansk
Tel. +48 (0) 58-5500700
Fax +48 (0) 58-5500700

Schweiz:

Airproduct AG

Bremgar tenstrasse 31
CH-8966 Oberwil-Lieli
Tel. +41 (0) 566339633
Fax +41 (0) 566339638

Türkei:

Günmak

Kompresör ve Makina
Sanayi ve Ticaret A.S.
Perpa Ticaret Merkezi Kat. 9
No. 1354
**TR-80270 Okmeydani-
Istanbul**
Tel. +90 (0) 2122215510
Fax +90 (0) 2122215509

Südafrika:

Hyper Pneumatics

Postbox 10499
Linton Grange
ZA-6015 Port Elizabeth
Tel. +27 (0) 413604686
Fax +27 (0) 413606255

USA:

Global Techsol

2400 E. Main Street
Suite 103 # 311
USA-St. Charles
IL 60175
Tel. +1 (630) 2581879
Fax +1 (630) 5131861



Umformtechnik GmbH

Postfach 1262/1263 · 58718 Fröndenbergr/Ruhr

fon Verkauf Inland +49 (0) 2373 755 300

fon Verkauf Ausland +49 (0) 2373 755 400

fax +49 (0) 2373 755 600

email info@honsel.de

web <http://www.honsel.de>